



## General Description (产品描述)

The SE3806 is a high-efficiency monolithic synchronous buck regulator using a constant frequency, current mode architecture. The device is available in an adjustable version. Supply current with no load is 40uA and drops to <1uA in shutdown. The 2.5V to 6V input voltage range makes the SE3806 ideally suited for single Li-Ion battery powered applications. 100% duty cycle provides low dropout operation, extending battery life in portable systems. PWM/PFM mode operation provides very low output ripple voltage for noise sensitive applications. Switching frequency is internally set at 1.5MHz, allowing the use of small surface mount inductors and capacitors. Low output voltages are easily supported with the 0.6V feedback reference voltage. The SE3806 is offered in a low profile (1mm) 5-pin, thin SOT package, and is available in an adjustable version.

## Features(产品特性)

- High Efficiency: Up to 96%
- 2.5V to 6V Input Voltage Range
- 1.5MHz Constant Frequency Operation
- No Schottky Diode Required
- Low Dropout Operation: 100% Duty Cycle
- PFM Mode for High Efficiency in Light Load
- Over temperature Protected
- Low Quiescent Current: 40μA
- Short Circuit Protection
- Inrush Current Limit and Soft Start
- SOT23-5 package

## Applications(产品应用)

- Cellular and Smart Phones
- Wireless and DSL Modems
- PDAs
- Portable Instruments
- Digital Still and Video Cameras
- PC Cards

## Typical Application (典型应用电路)

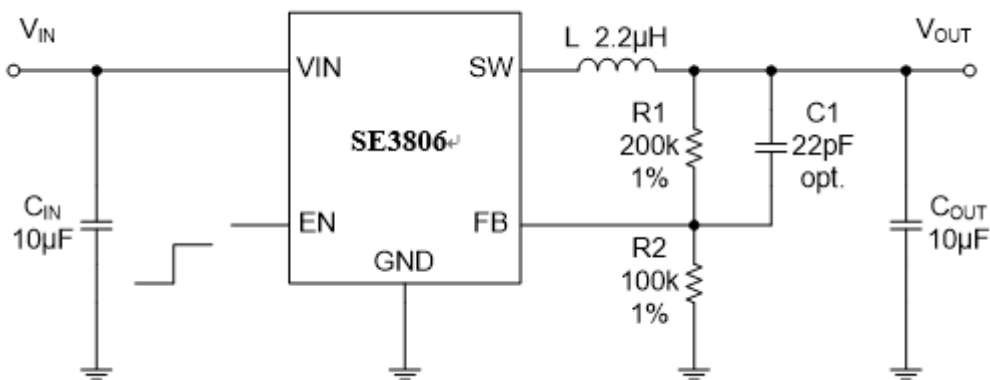



### Pin Configuration (管脚排列)

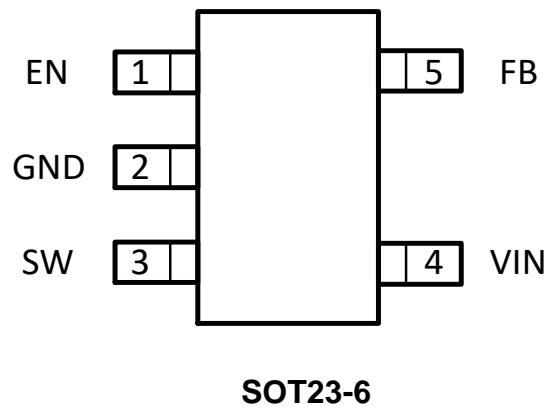

### Pin Description (管脚功能描述)

NO.	Pin Name	Pin Function Description
1	EN	Chip Enable Pin. Drive EN above 1.5V to turn on the part. Drive EN below 0.3V to turn it off. Do not leave EN floating.
2	GND	Ground Pin
3	SW	Power Switch Output. It is the switch node connection to Inductor. This pin connects to the drains of the internal P-ch and N-ch MOSFET switches.
4	VIN	Power Supply Input. Must be closely decoupled to GND with a 10 $\mu$ F or greater ceramic capacitor.
5	FB	Output Voltage Feedback Pin. An internal resistive divider divides the output voltage down for comparison to the internal reference voltage.

### Functional Block Diagram (功能框图)

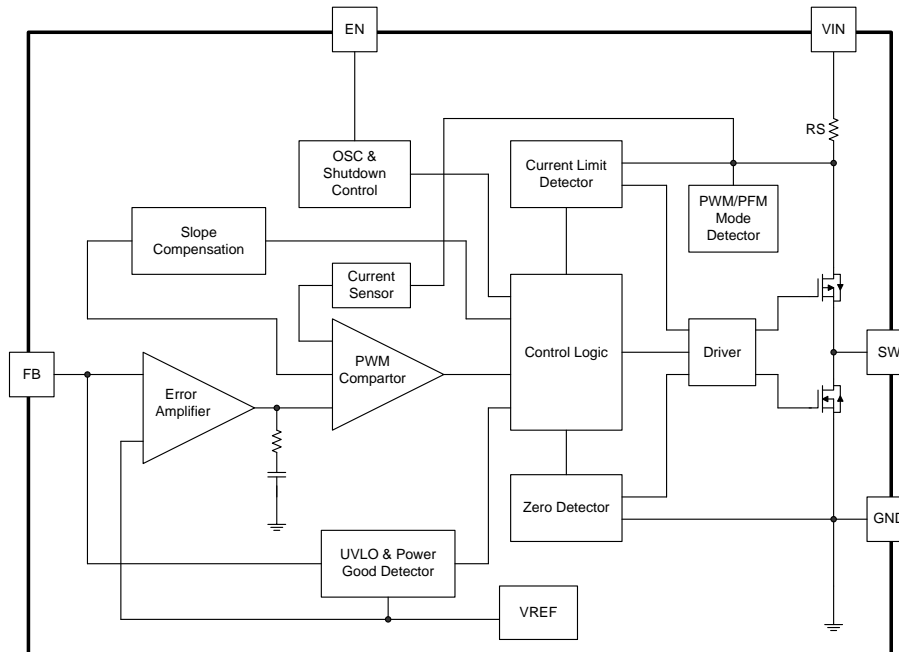

### Ordering Information (订货信息)

Part Number	Marking Information	Package	Remarks
SE3806-HF	KL6YM	SOT23-6	K: 降压系列 L: Vin=2.5~ 6V 6: SE3816 YM: Year&Month (1-9,0,A,B) HF: 无卤素

### Absolute Maximum Ratings(最大额定参数)

Symbol	Parameter	Maximum	Units
Vin, Voltage		-0.3V to 6V	V
EN,FB Voltages		-0.3 to 6V	V
SW Voltage		-0.3Vto VIN+0.3V	V
Power Dissipation	P <sub>D</sub>	455	mW
Thermal Resistance	θ <sub>JA</sub>	+220	°C/W
Junction Temperature	T <sub>J</sub>	+150	°C
Operating Temperature	T <sub>OP</sub>	-40 to +85	°C
Storage Temperature	T <sub>ST</sub>	-65 to 150	°C
Lead Temperature (Soldering, 10 sec)		+300	°C



**Electrical Characteristics(电气参数)**

(VIN=3.6V,TA = 25°C, unless otherwise noted)

Symbol	Test Conditions	Min	Typ	Max	Unit
Input Voltage Range		2.5		6.0	V
UVLO Threshold			2.4		V
Input DC Supply Current	FB = 90%, Iload=0mA		150	300	μA
	FB= 105%, Iload=0mA		40	70	μA
	VEN = 0V, VIN=4.2V		0.1	1.0	μA
Regulated Feedback Voltage	TA = 25°C	0.588	0.600	0.612	V
Reference Voltage Line Regulation	Vin = 2.5V to 6.0V		0.04	0.40	%/V
Output Voltage Line Regulation	VIN = 2.5V to 6.0V		0.04	0.4	%
Output Voltage Load Regulation			0.5		%
Oscillation Frequency			1.5		MHz
On Resistance of PMOS	ISW=100mA		0.3		Ω
ON Resistance of NMOS	ISW=-100mA		0.2		Ω
Peak Current Limit	VIN= 3.6V, FB=90%	1.5			A
EN Threshold		0.30	1.0	1.50	V
EN Leakage Current			±0.01	±1.0	μA
SW Leakage Current	VEN=0V,VIN=Vsw=5V		±0.01	±1.0	μA
Thermal Shutdown			160		°C

Note 1: Absolute Maximum Ratings are those values beyond which the life of a device may be impaired.

Note 2: TJ is calculated from the ambient temperature TA and power dissipation PD according to the following formula:

$$T_J = T_A + (P_D) \times (250^\circ\text{C/W}).$$

Note3: 100% production test at +25°C. Specifications over the temperature range are guaranteed by design and characterization.



## Functional Description(功能介绍)

### Operation

The SE3806 uses a constant frequency, current mode step-down architecture. Both the main (P-channel MOSFET) and synchronous (N-channel MOSFET) switches are internal. During normal operation, the internal top power MOSFET is turned on each cycle when the oscillator sets the RS latch, and turned off when the current comparator, ICOMP, resets the RS latch. The peak inductor current at which ICOMP resets the RS latch, is controlled by the output of error amplifier EA. When the load current increases, it causes a slight decrease in the feedback voltage, FB, relative to the 0.6V reference, which in turn, causes the EA amplifier's output voltage to increase until the average inductor current matches the new load current. While the top MOSFET is off, the bottom MOSFET is turned on until either the inductor current starts to reverse, as indicated by the current reversal comparator IRCMP, or the beginning of the next clock cycle.

## Applications Information(应用信息)

### Setting the Output Voltage

In the adjustable version, the output voltage is set by a resistive divider according to the following formula:

$$R_2 = \frac{R_1}{V_{out} / V_{FB} - 1}$$

The external resistive divider is connected to the output, allowing remote voltage sensing as shown in on page 1 .

### Inductor Selection

For most designs, the SE3806 operates with inductors of 1μH to 4.7μH. Low inductance values are

physically smaller but require faster switching, which results in some efficiency loss. The inductor value can be derived from the following equation:

$$L = \frac{V_{OUT} \times (V_{IN} - V_{OUT})}{V_{IN} \times \Delta I_L \times f_{OSC}}$$

Where  $\Delta I_L$  is inductor Ripple Current. Large value inductors result in lower ripple current and small value inductors result in high ripple current. For optimum voltage-positioning load transients, choose an inductor with DC series resistance in the 50mΩ to 150mΩ range.

### Input Capacitor Selection

Higher values, lower cost ceramic capacitors are now becoming available in smaller case sizes. Their high ripple current, high voltage rating and low ESR make them ideal for switching regulator applications. Because the SE3806's control loop does not depend on the output capacitor's ESR for stable operation, ceramic capacitors can be used freely to achieve very low output ripple and small circuit size. However, care must be taken when ceramic capacitors are used at the input and the output. When a ceramic capacitor is used at the input and the power is supplied by a wall adapter through long wires, a load step at the output can induce ringing at the input, VIN. At best, this ringing can couple to the output and be mistaken as loop instability. At worst, a sudden inrush of current through the long wires can potentially cause a voltage spike at VIN, large enough to damage the part. When choosing the input and output ceramic capacitors, choose the X5R or X7R dielectric formulations. These dielectrics have the best temperature and voltage



and size.

characteristics of all the ceramics for a given value

### PC Board Layout Checklist

When laying out the printed circuit board, the following checking should be used to ensure proper operation of the SE3806. Check the following in your layout::

1. The power traces, consisting of the GND trace, the SW trace and the VIN trace should be kept short, direct and wide.
2. Does the (+) plates of Cin connect to Vin as closely as possible? This capacitor provides the AC current to the internal power MOSFETs.
3. Keep the switching node, SW, away from the sensitive VOUT node.
4. Keep the (-) plates of Cin and Cout as close as possible.



**Outline Drawing For SOT23-6 (封装尺寸 SOT23-6)**

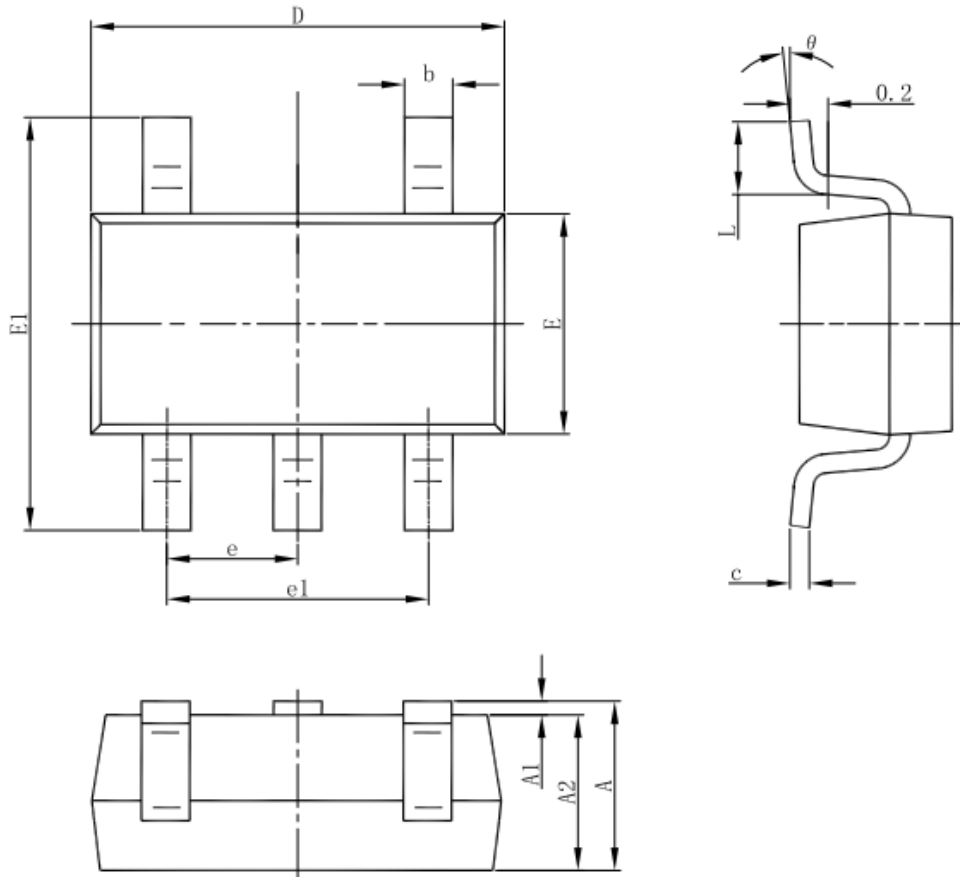

Symbol	Dimensions In Millimeters		Dimensions In Inches	
	Min	Max	Min	Max
A	1.050	1.250	0.041	0.049
A1	0.000	0.100	0.000	0.004
A2	1.050	1.150	0.041	0.045
b	0.300	0.500	0.012	0.020
c	0.100	0.200	0.004	0.008
D	2.820	3.020	0.111	0.119
E	1.500	1.700	0.059	0.067
E1	2.650	2.950	0.104	0.116
e	0.950(BSC)		0.037(BSC)	
e1	1.800	2.000	0.071	0.079
L	0.300	0.600	0.012	0.024
θ	0°	8°	0°	8°



**联系方式:**

北京思旺电子有限公司-中国总部

地址: 中国北京市海淀区信息路 22 号上地科技综合楼 B 座二层

邮编: 100085

电话:010-82895700/1/5

传真:010-82895706

Seaward Electronics Corporation – 台湾办事处

2F, #181, Sec. 3, Minguan East Rd,

Taipei, Taiwan R.O.C

电话: 886-2-2712-0307

传真: 886-2-2712-0191

Seaward Electronics Incorporated – 北美办事处

1512 Centre Pointe Dr.

Milpitas, CA95035, USA

电话: 1-408-821-6600